



TECHNICAL DATA

MASSES

Basic mass	277 kg
Operating mass	280 kg

COMPACTION

Amplitude	1.4 mm
Centrifugal force	40 kN
Frequency	80 Hz

TRACTION

Max. gradeability	32 %
Max. working speed	27 m/min

ENGINE

Manufacturer/Model	Hatz 1B20
Emissions according to	EU Stage V/non US EPA
Type	Air cooled diesel
Number of cylinders	1
Fuel tank capacity	3.0 l
Power	3.1 kW @ 3000 rpm
Fuel consumption l /h, avg	0.7 l/h

DRIVE SYSTEM

Drive system	Mechanical
--------------	------------

Find us locally at www.dynapac.com

We reserve the right to change specifications without notice. Photos and illustrations do not always show standard versions of machines. The above information is a general description only, all informations are supplied without liability.



DIMENSIONS

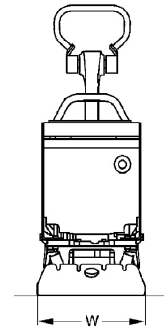
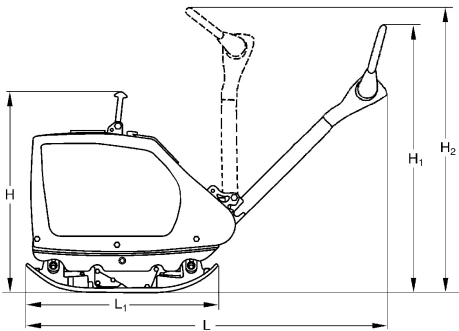

DIMENSIONS

H. Height	700 mm
H1. Height, steering rod (lowered)	1030 mm
H2. Height, steering rod (raised)	1150 mm
L. Length	1405 mm
L1. Length	762 mm
W. Basic plate width	600 mm

STANDARD FEATURES OPTIONAL EQUIPMENT

- | | |
|---|---|
| <ul style="list-style-type: none"> ■ Control handle with vibration isolation ■ Height adjustable control lever ■ Control lever lock in transport and working position ■ Reverse drive protection ■ Highly wear resistant base plate ■ All around protection hood ■ All around protection for V-belt ■ Automatic decompression ■ One point lift ■ Recoil starter ■ Electric starter ■ Hour meter | <ul style="list-style-type: none"> ■ Block paving mat ■ Puncture proof transport wheels (+5kg) ■ Service Kit |
|---|---|

Find us locally at www.dynapac.com

We reserve the right to change specifications without notice. Photos and illustrations do not always show standard versions of machines. The above information is a general description only, all informations are supplied without liability.